

**U1**  
**TMS320VC5509A-GHH**

<b>Spectrum Digital Incorporated</b>		
Title: TMS320VC5509A EVM PL US		
Size B	Document Number 507752	Rev A
Date: Tuesday, July 27, 2004	Sheet 2 of 23	

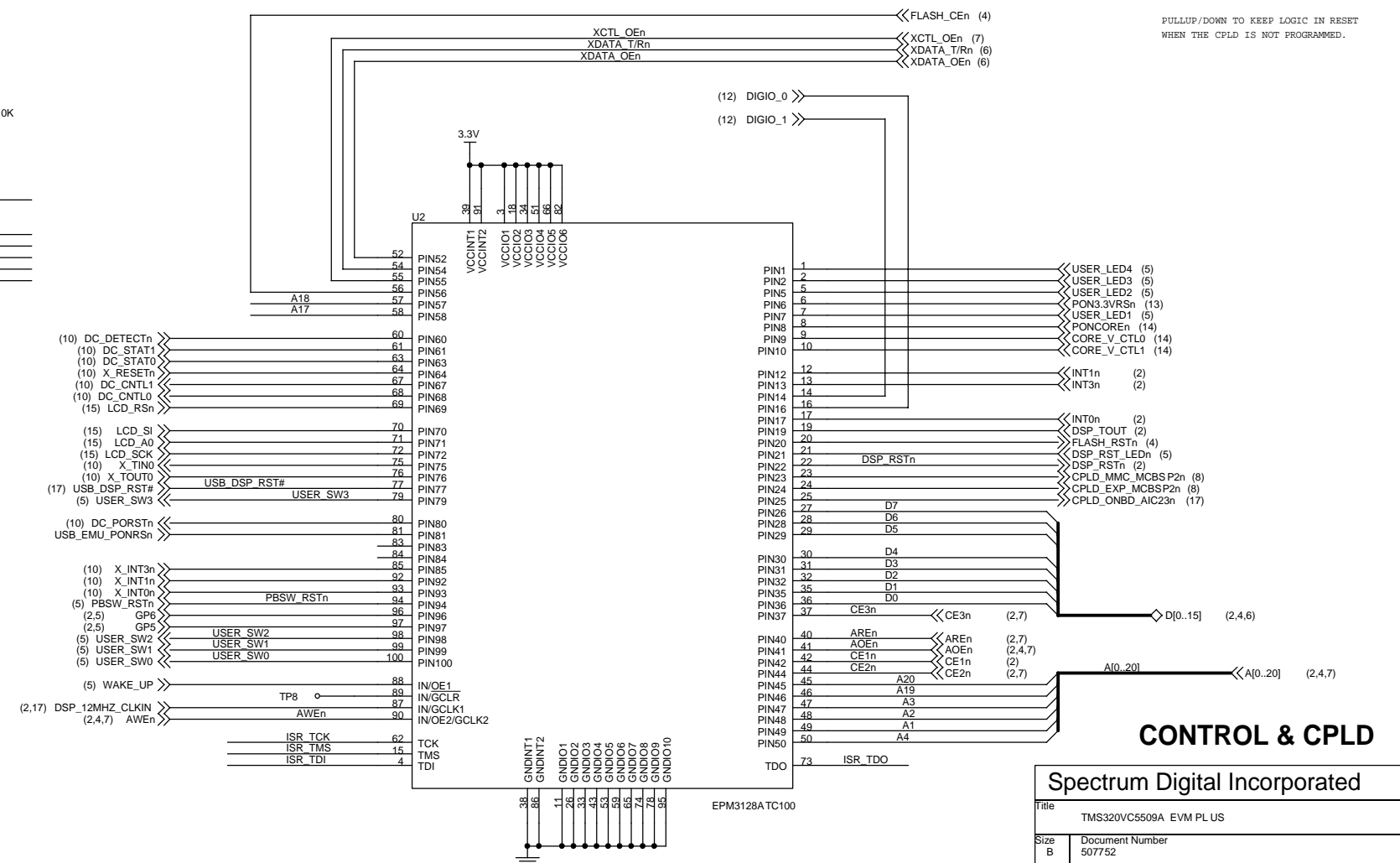
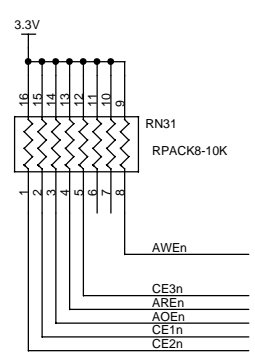
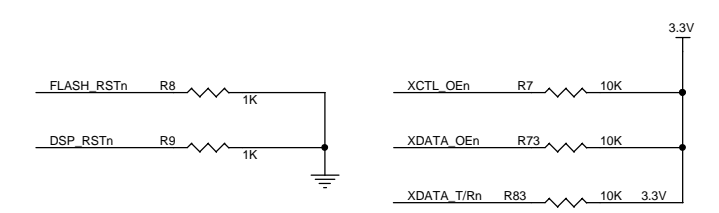
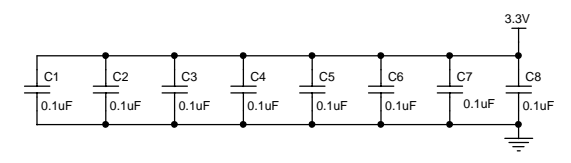
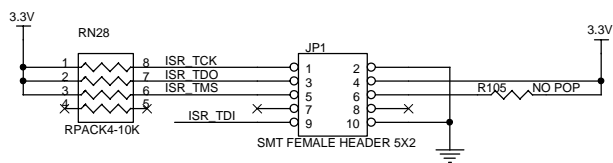

### CONTROL & CPLD

Spectrum Digital Incorporated		
Title: TMS320VC5509A EVM PL US		
Size B	Document Number 507752	Rev A
Date: Tuesday, July 27, 2004	Sheet 3	of 23

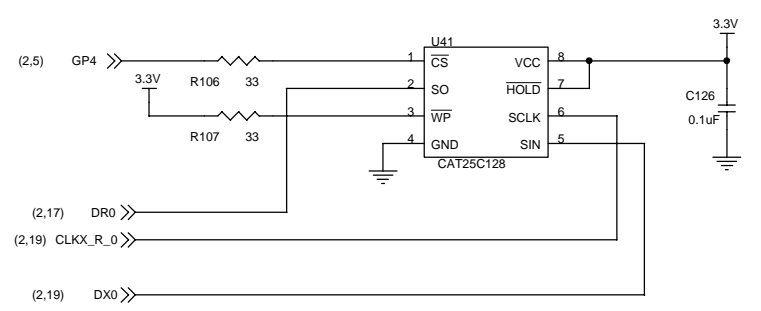
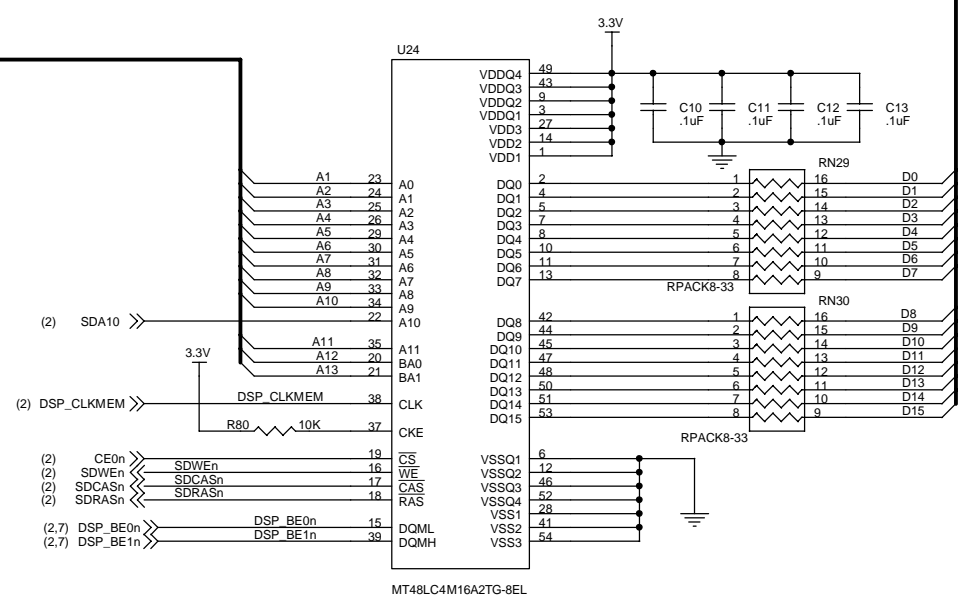
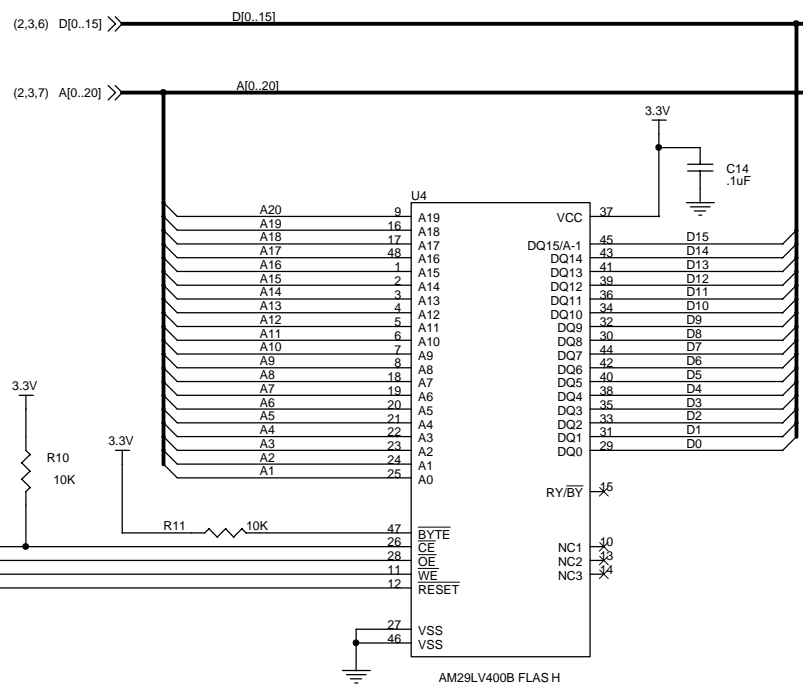

SPI Boot Memory **MEMORY - FLASH/SDRAM**

<b>Spectrum Digital Incorporated</b>		
Title: TMS320VC5509A EVM PL US		
Size B	Document Number 507752	Rev A
Date: Tuesday, July 27, 2004	Sheet 4	of 23

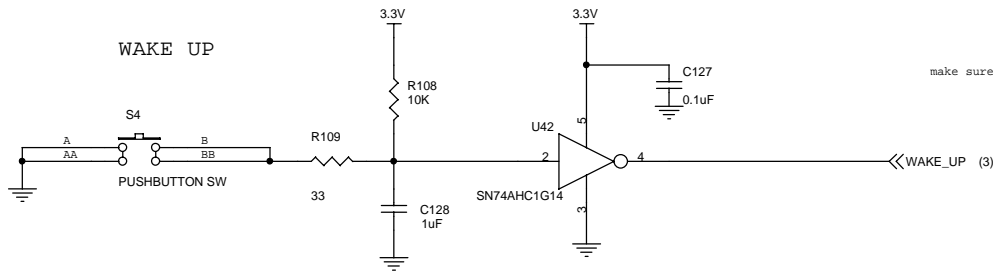
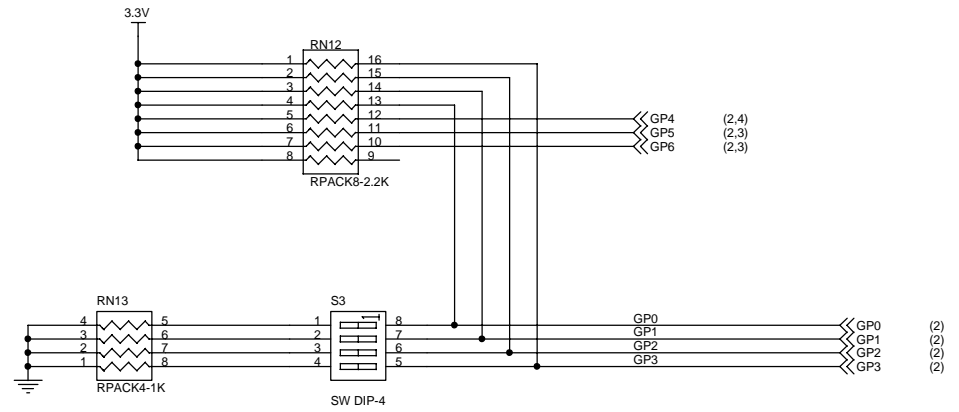
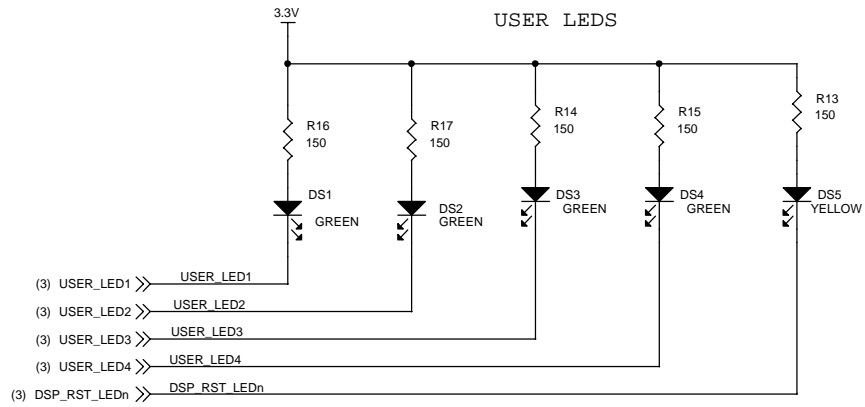

make sure switch lines up with on/off

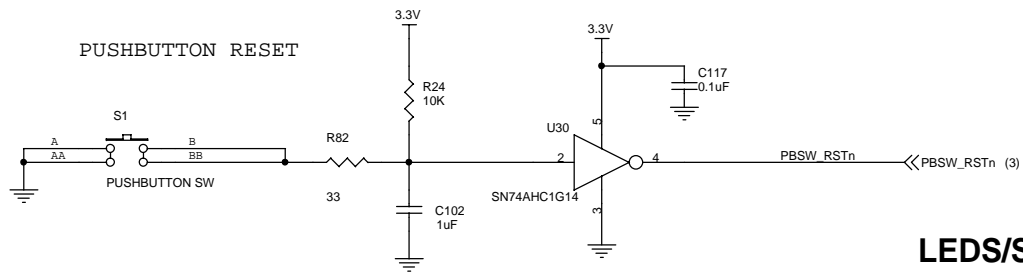
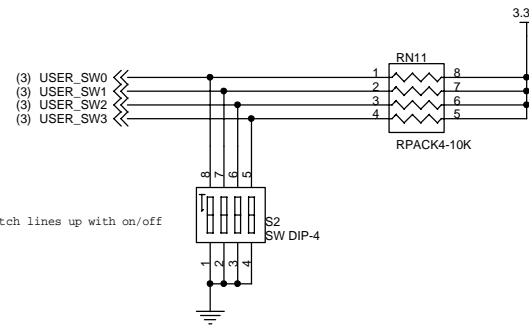

## LEDS/SWITCHES

**Spectrum Digital Incorporated**

Title		
TMS320VC5509A EVM PL US		
Size B	Document Number	Rev
	507752	A
Date: Tuesday, July 27, 2004		Sheet 5 of 23

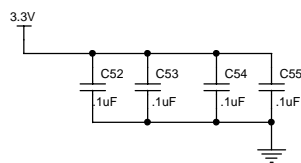
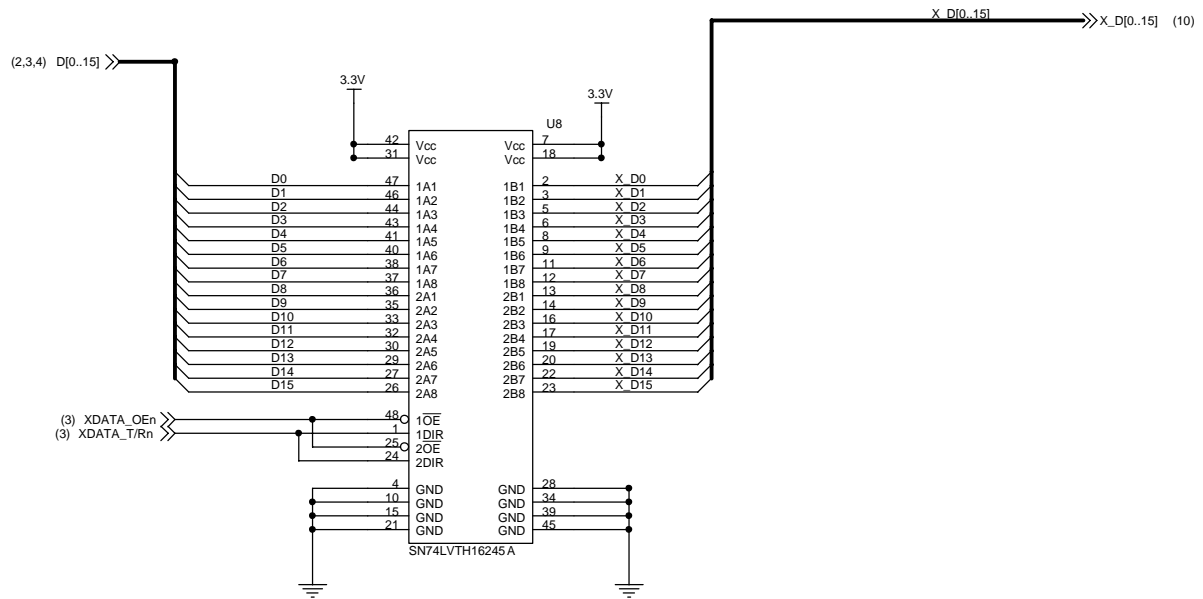

## EXPANSION DATA BUFFERS

Spectrum Digital Incorporated

Title		
TMS320VC5509A EVM PL US		
Size B	Document Number	Rev
	507752	A
Date:	Tuesday, July 27, 2004	Sheet 6 of 23

(2,3,4) A[0..20] >>

A[0..20]

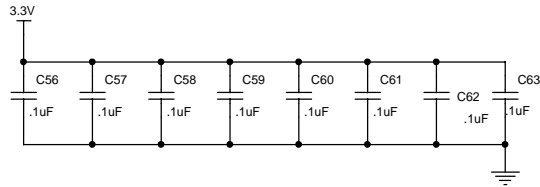
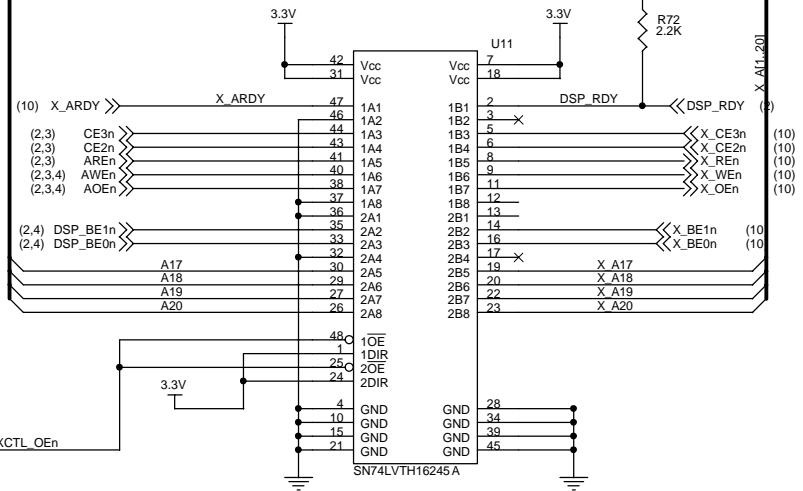
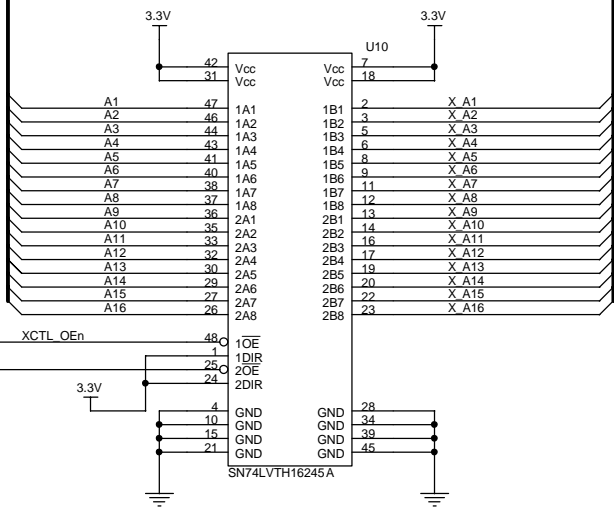

### EXPANSION ADDR, CONTROL BUFFERS

Spectrum Digital Incorporated		
Title TMS320VC5509A EVM PL US		
Size B	Document Number 507752	Rev A
Date: Tuesday, July 27, 2004	Sheet 7	of 23

### McBSP0 BUFFER

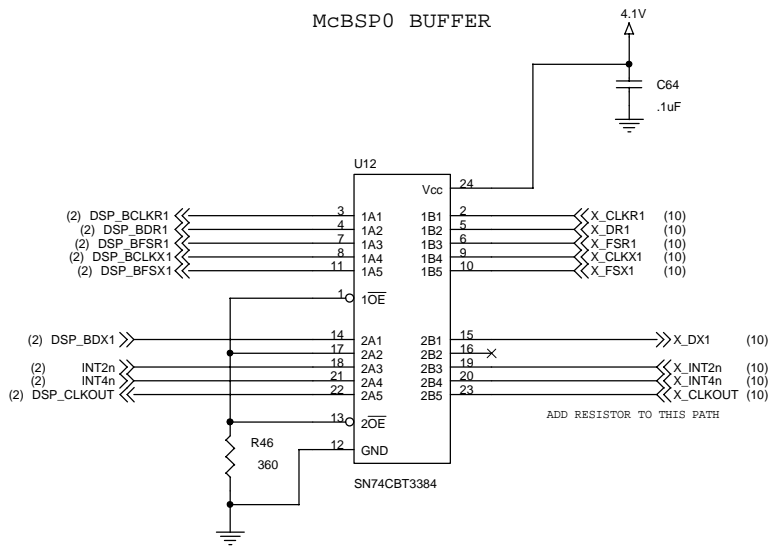

### McBSP1 BUFFER

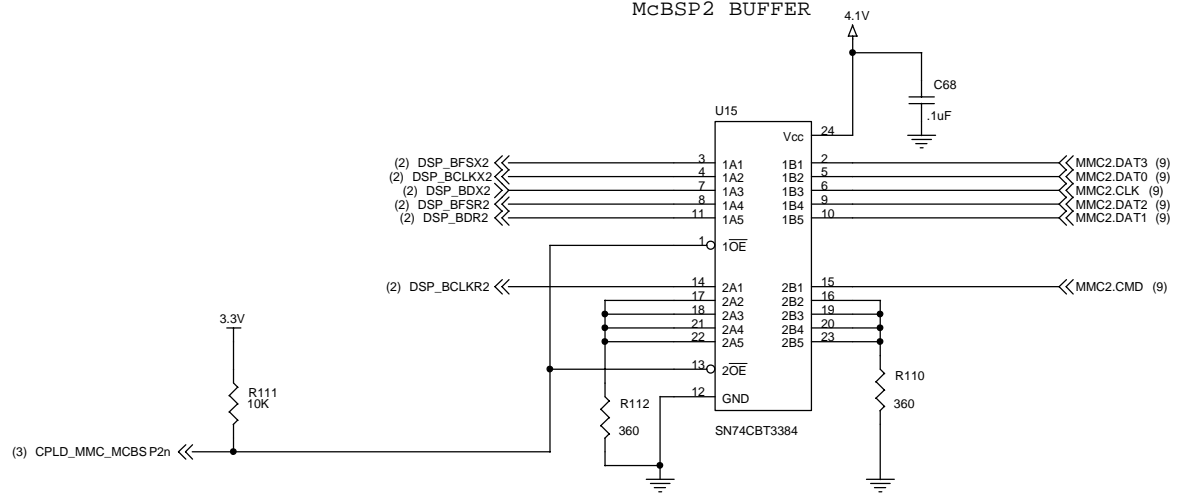

### McBSP2 BUFFER

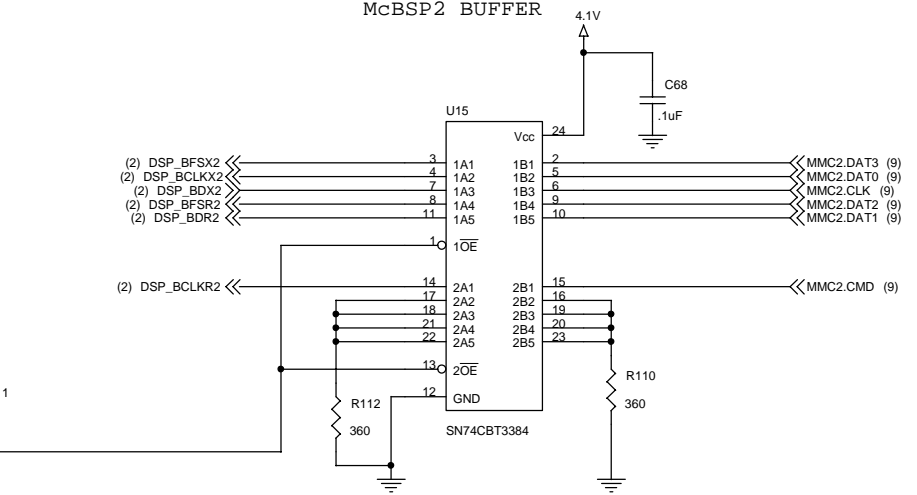

## SERIAL PORT BUFFER

Spectrum Digital Incorporated

Title		
TMS320VC5509A EVM PL US		
Size	Document Number	Rev
B	507752	A
Date:	Tuesday, July 27, 2004	Sheet 8 of 23



# MMC and ALT Media Connectors

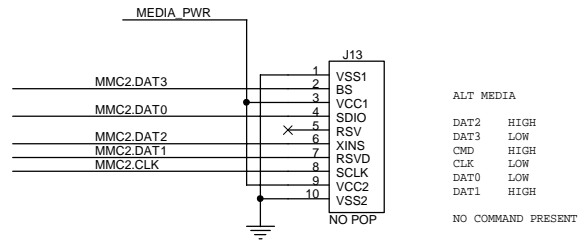
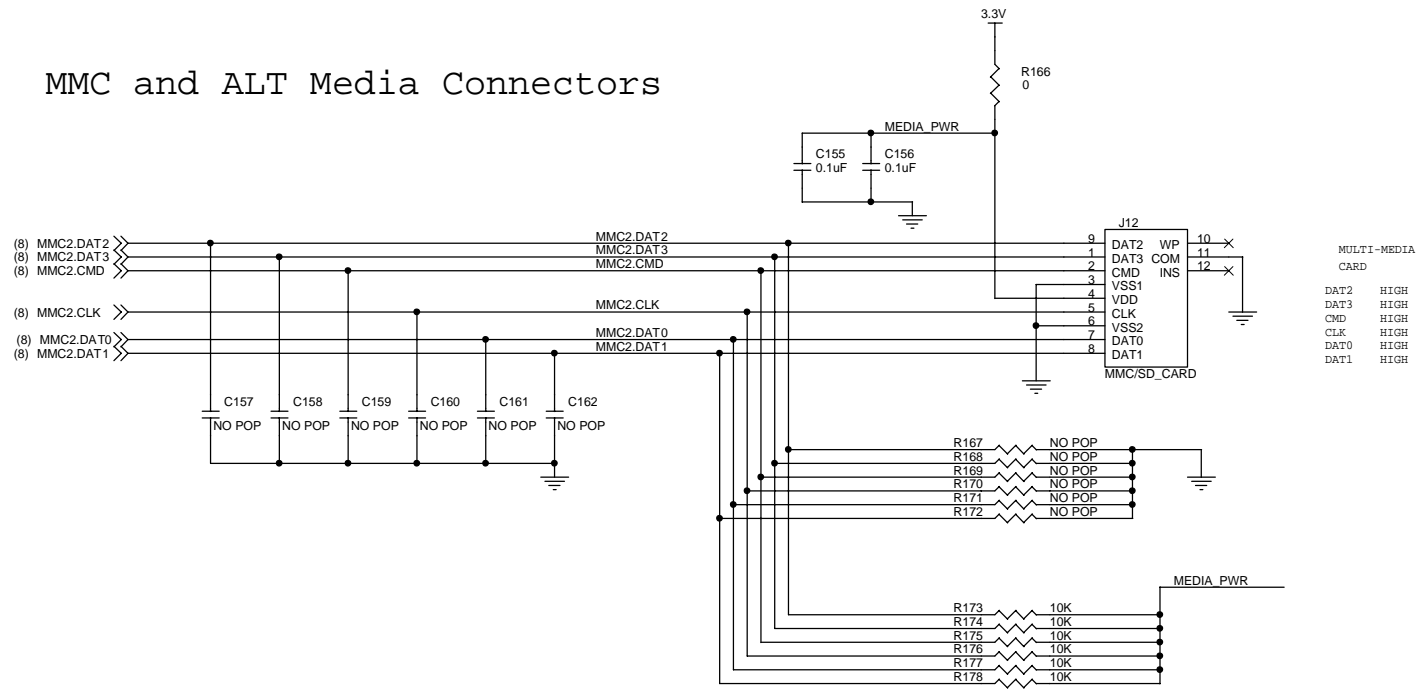

<b>Spectrum Digital Incorporated</b>		
Title TMS320VC5509A EVM PL US		
Size B	Document Number 507752	Rev A
Date: Tuesday, July 27, 2004	Sheet 9 of 23	

# MEMORY INTERFACE

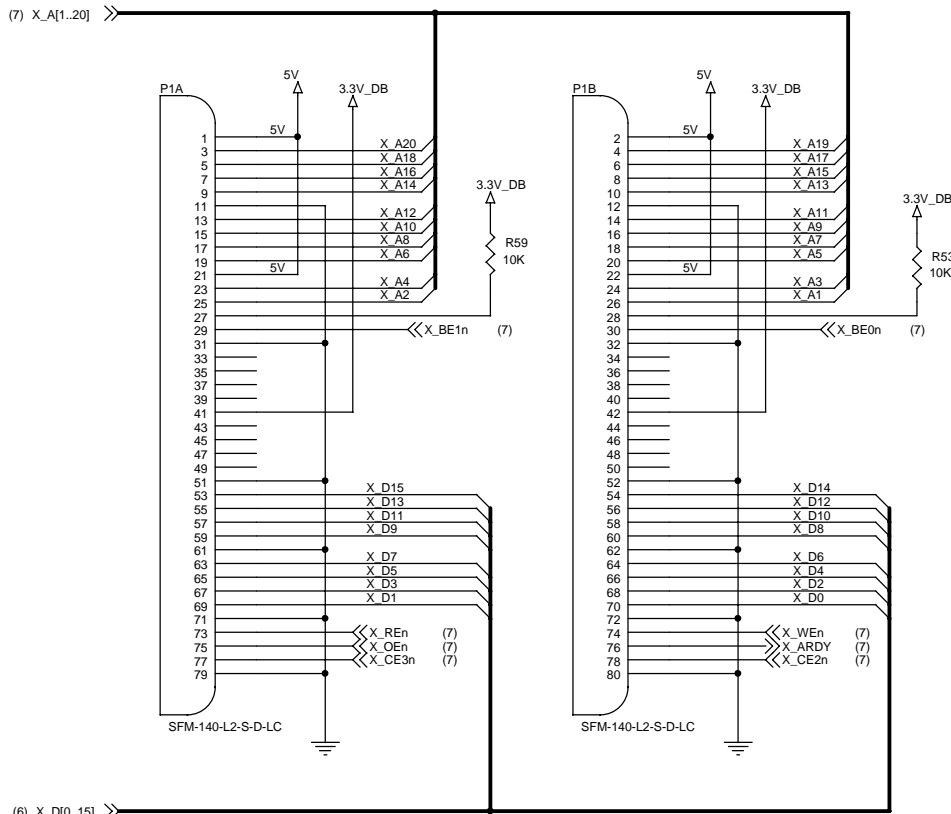

# EXPANSION BUS CE2

# PERIPHERAL INTERFACE

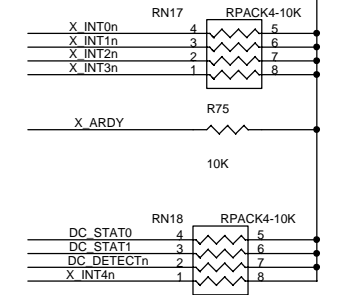
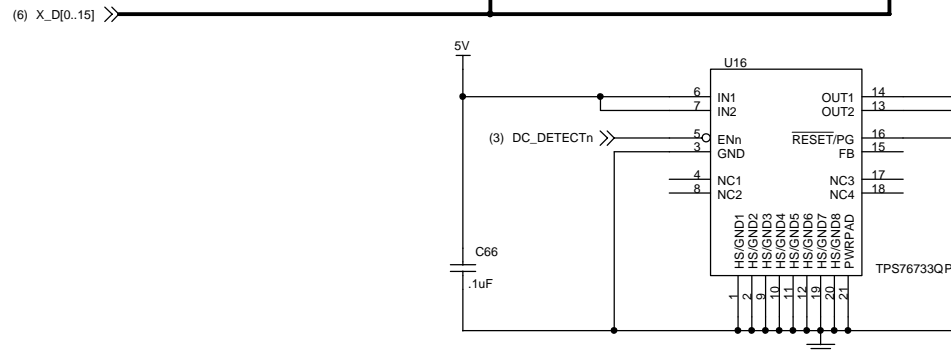
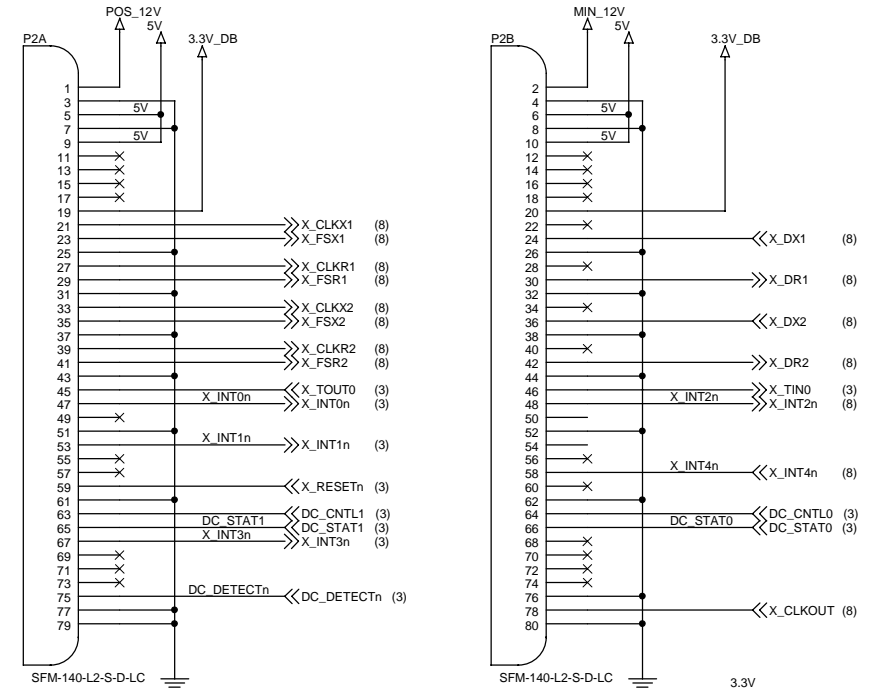

# DB MEMORY/PERIPHERAL INTERFACES

# Spectrum Digital Incorporated

Title		
TMS320VC5509A EVM PL US		
Size	Document Number	Rev
B	507752	A
Date:	Tuesday, July 27, 2004	Sheet 10 of 23

EXTERNAL POWER PLUG

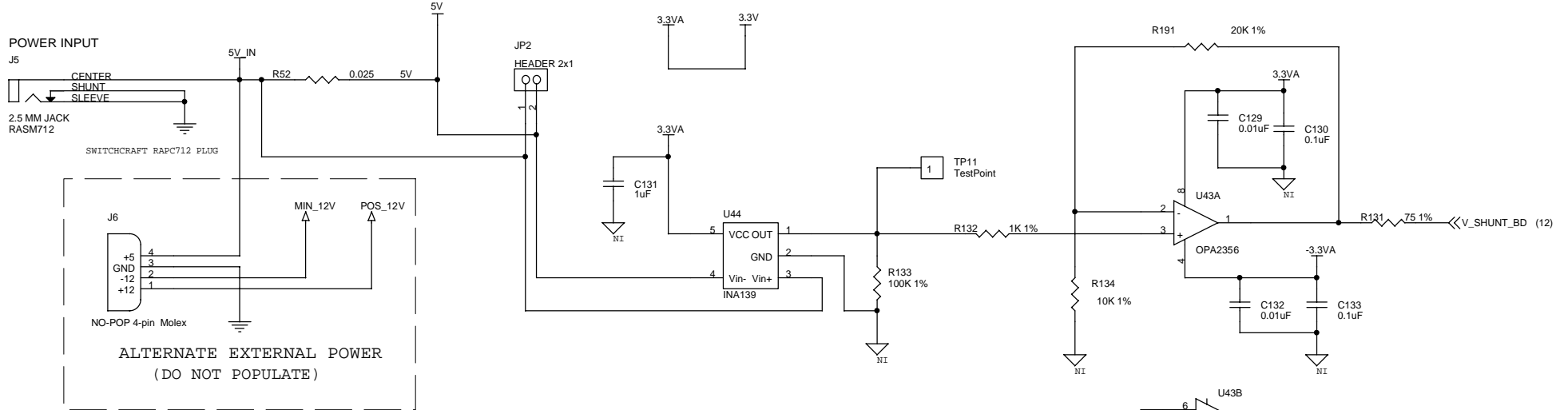

INPUT POWER

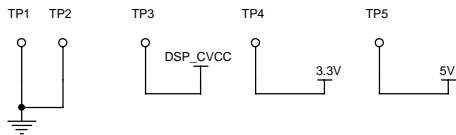
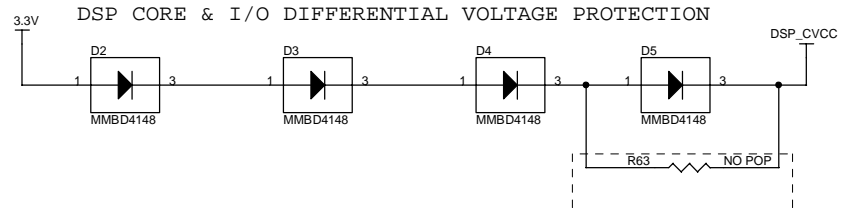

GROUND TEST POINTS

DAUGHTERCARD STANDOFF GROUNDING

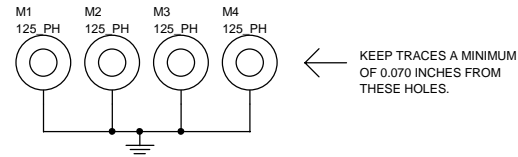

Spectrum Digital Incorporated

Title		
TMS320VC5509A EVM PL US		
Size	Document Number	Rev
B	507752	A
Date:	Tuesday, July 27, 2004	Sheet 11 of 23

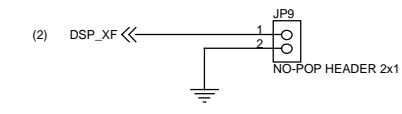
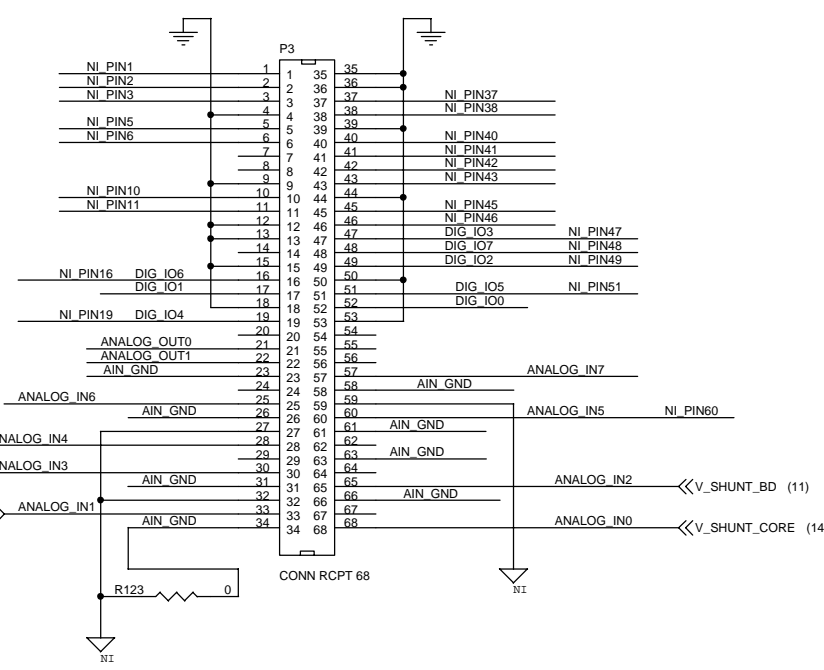
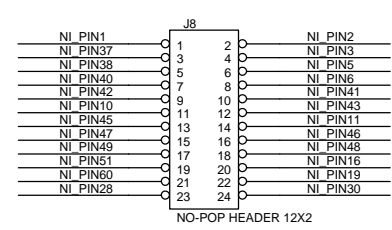
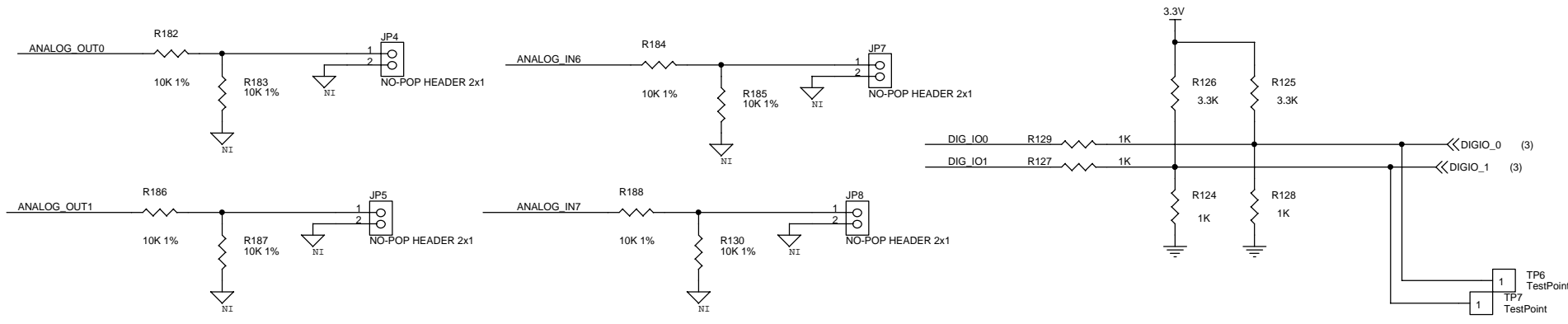

<b>Spectrum Digital Incorporated</b>		
Title TMS320VC5509A EVM PL US		
Size B	Document Number 507752	Rev A
Date: Tuesday, July 27, 2004	Sheet 12	of 23

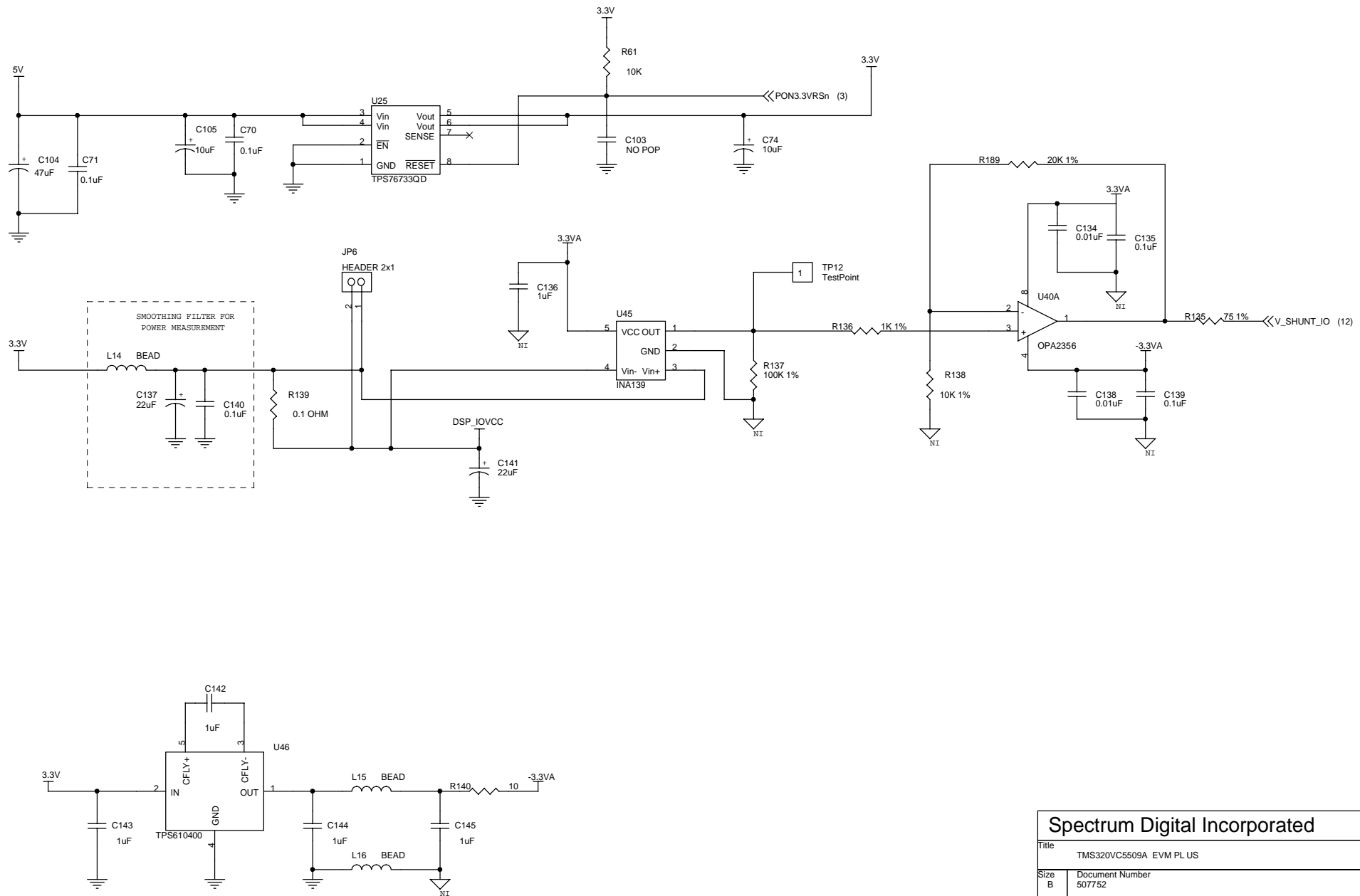

<b>Spectrum Digital Incorporated</b>		
Title TMS320VC5509A EVM PL US		
Size B	Document Number 507752	Rev A
Date: Tuesday, July 27, 2004	Sheet 13 of 23	

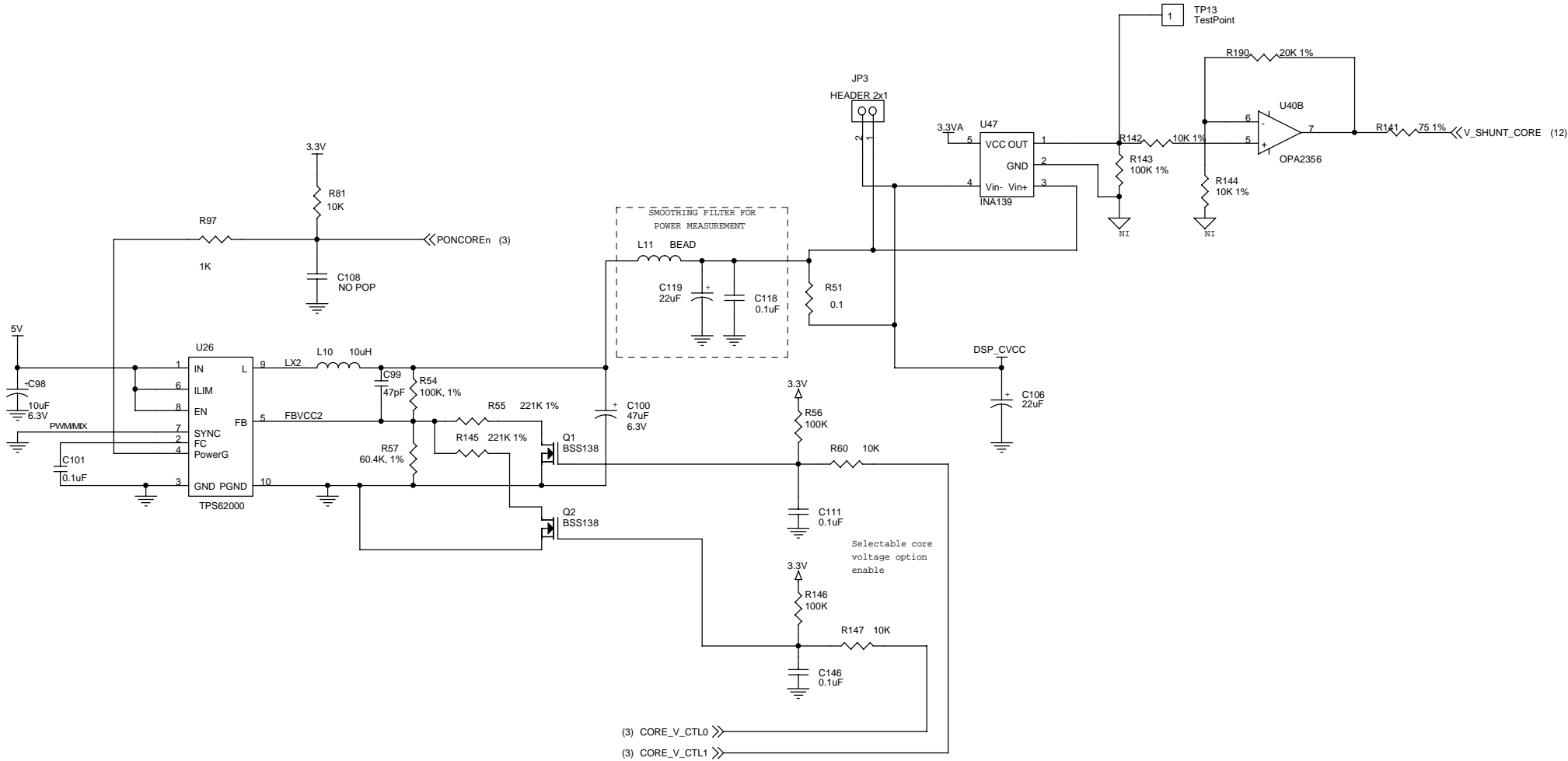

<b>Spectrum Digital Incorporated</b>		
Title		
TMS320VC5509A EVM PL US		
Size	Document Number	Rev
B	507752	A
Date:	Tuesday, July 27, 2004	Sheet 14 of 23

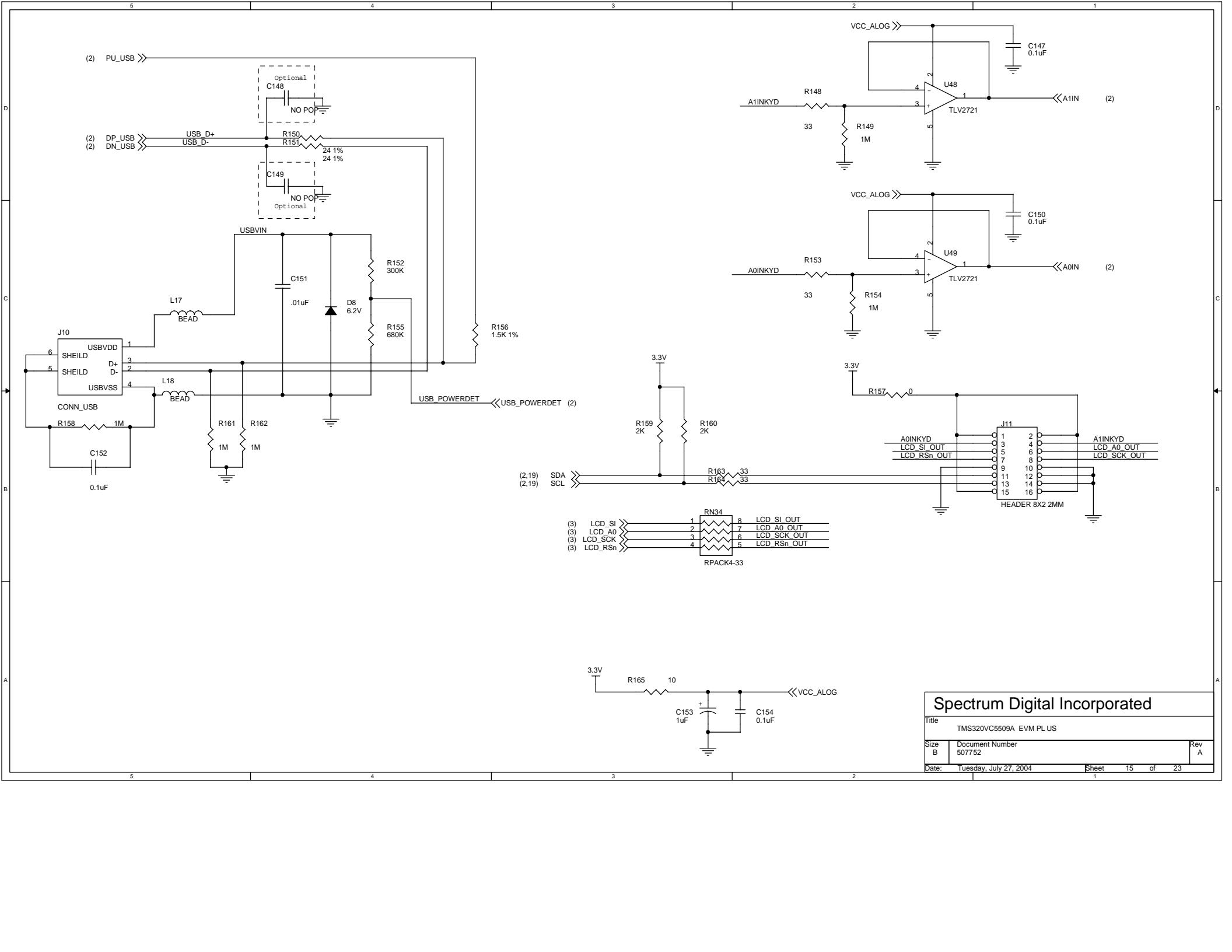

<b>Spectrum Digital Incorporated</b>		
Title TMS320VC5509A EVM PL US		
Size B	Document Number 507752	Rev A
Date: Tuesday, July 27, 2004	Sheet 15	of 23

### DSP JTAG HEADER

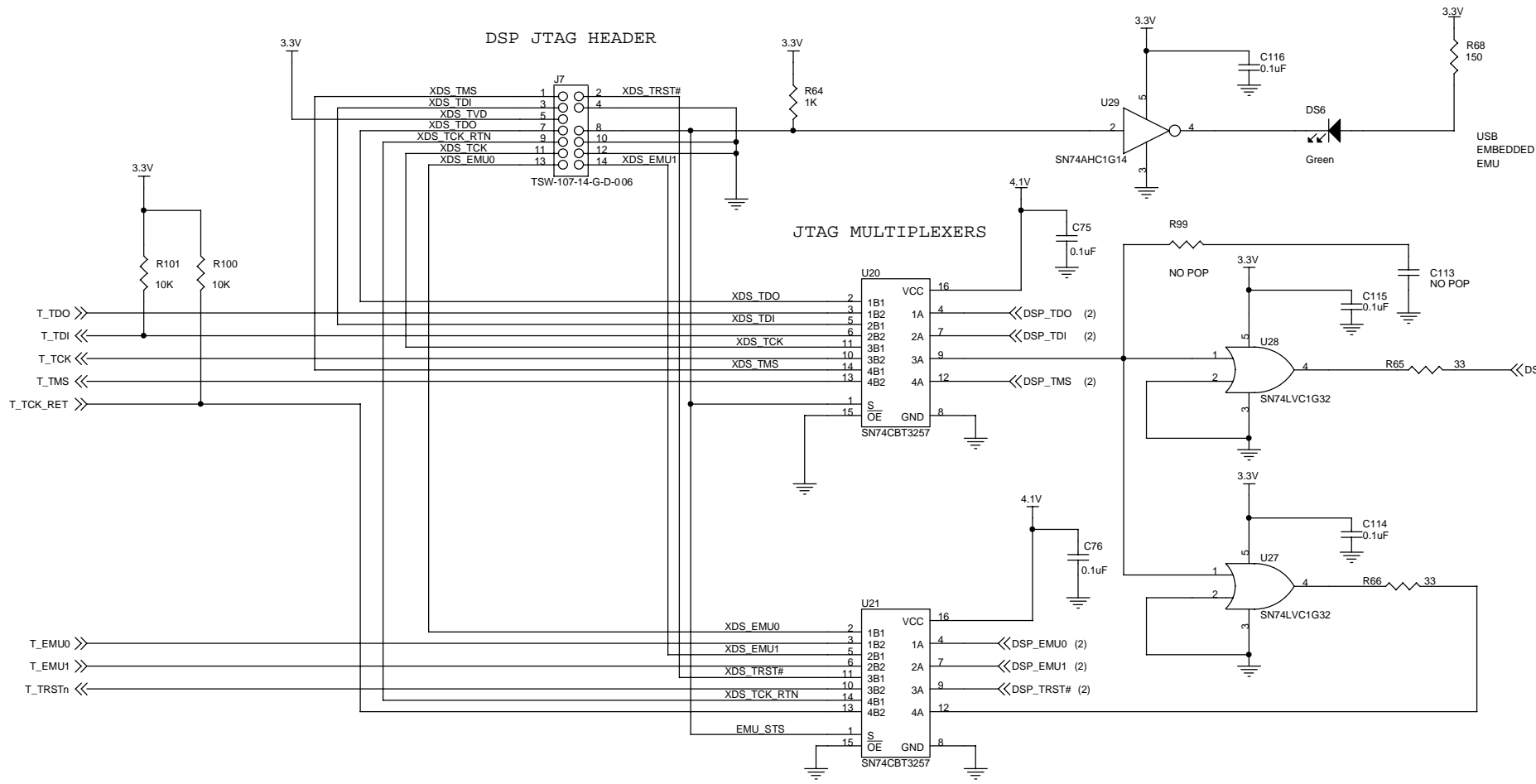

### CBT VOLTAGE DIVIDER

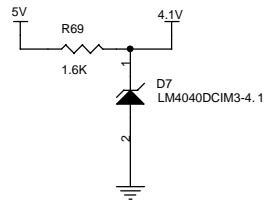

## JTAG INTERFACE

Spectrum Digital Incorporated

Title		
TMS320VC5509A EVM PL US		
Size	Document Number	Rev
B	506202	B
Date:	Tuesday, July 27, 2004	Sheet 16 of 23



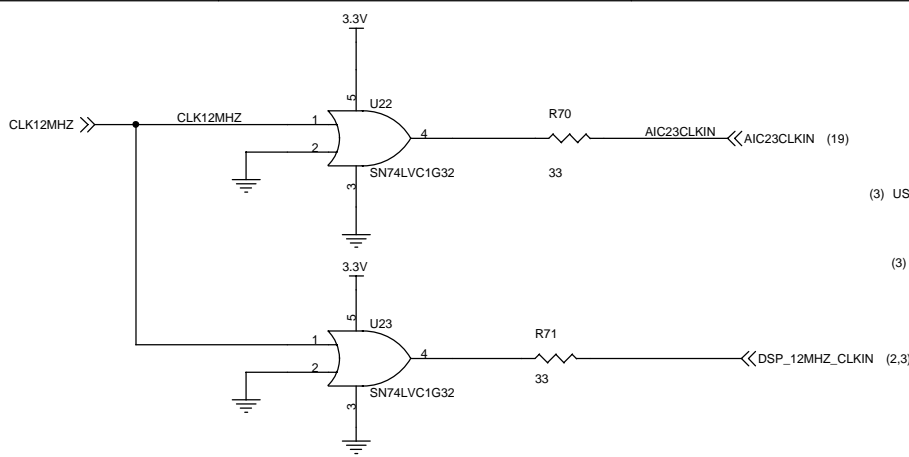

THESE GATES NEED TO BE PLACED CLOSE TO USB CLOCK SOURCE

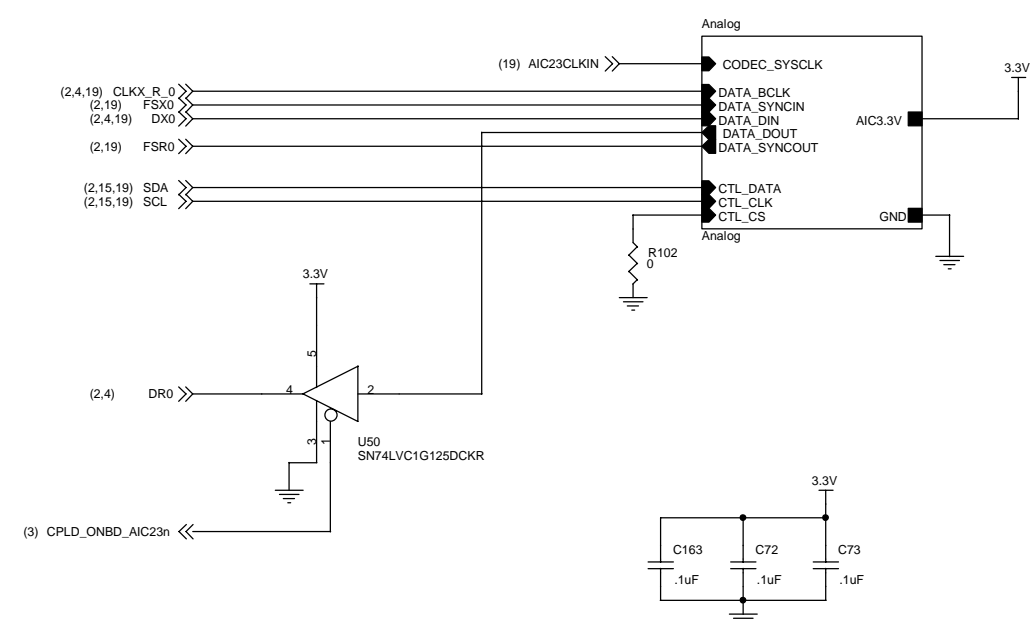
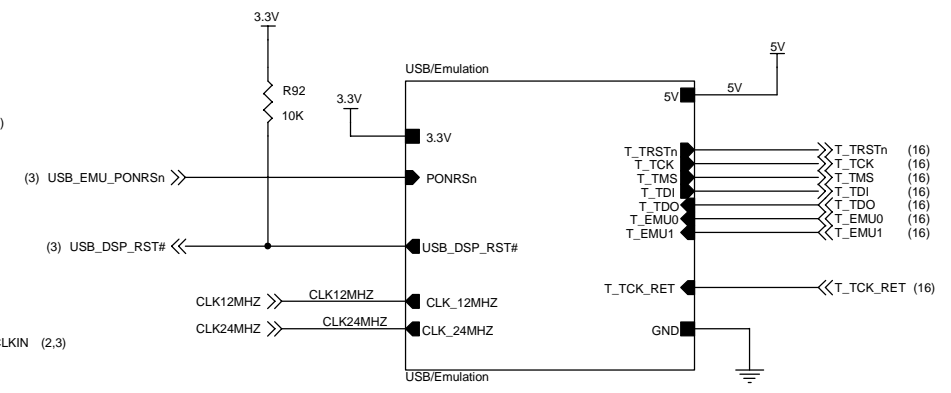

## Hierarchical Blocks

Spectrum Digital Incorporated		
Title TMS320VC5509A EVM PL US		
Size B	Document Number 507752	Rev A
Date: Tuesday, July 27, 2004	Sheet 17	of 23

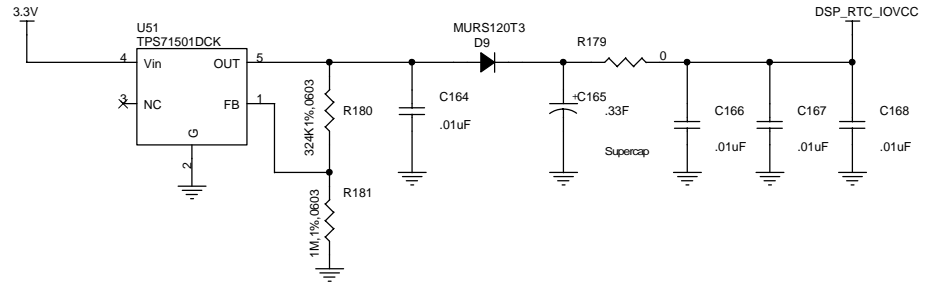
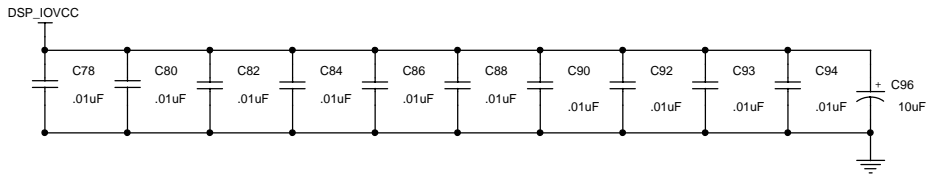
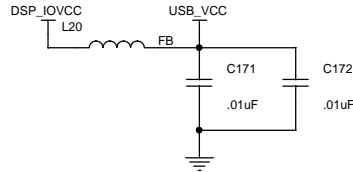
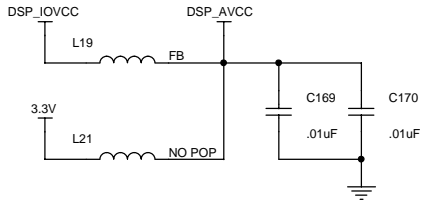
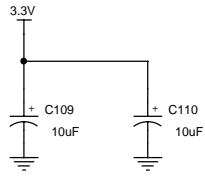
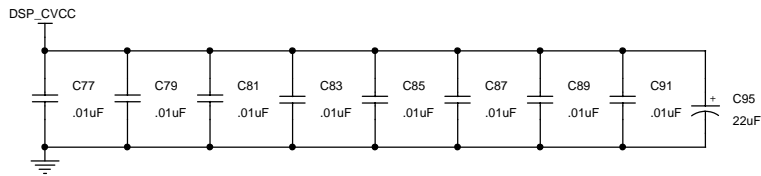

## DECOUPLING CAPS

Spectrum Digital Incorporated

Title		
TMS320VC5509A EVM PL US		
Size	Document Number	Rev
B	507752	A
Date:	Tuesday, July 27, 2004	Sheet 18 of 23

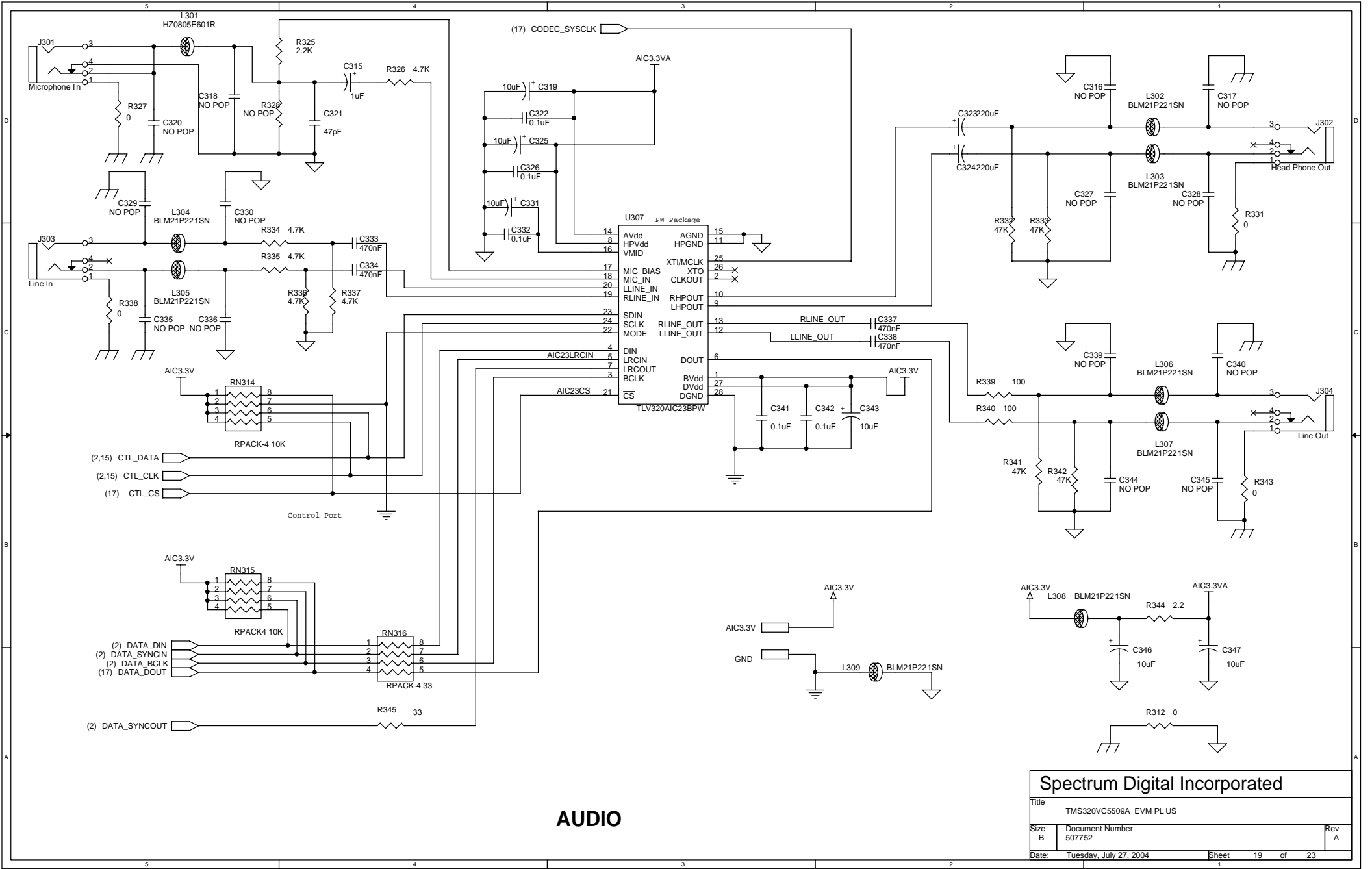

# AUDIO

<b>Spectrum Digital Incorporated</b>		
Title: TMS320VC5509A EVM PL US		
Size B	Document Number 507752	Rev A
Date: Tuesday, July 27, 2004	Sheet 19	of 23